

3/4" NPS HDPE Bung  
#180140

2" NPS HDPE Bung  
#180139

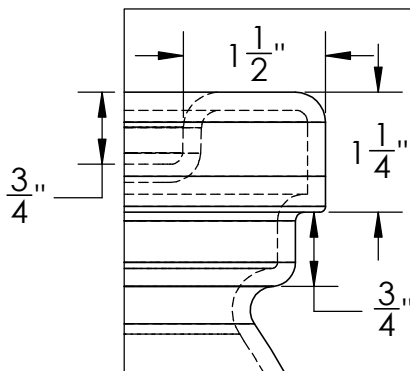

DETAIL A

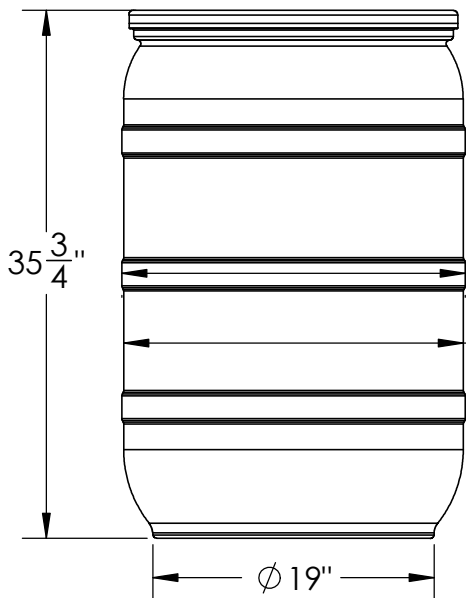

2" NPT x 1" DP.  
molded in threads

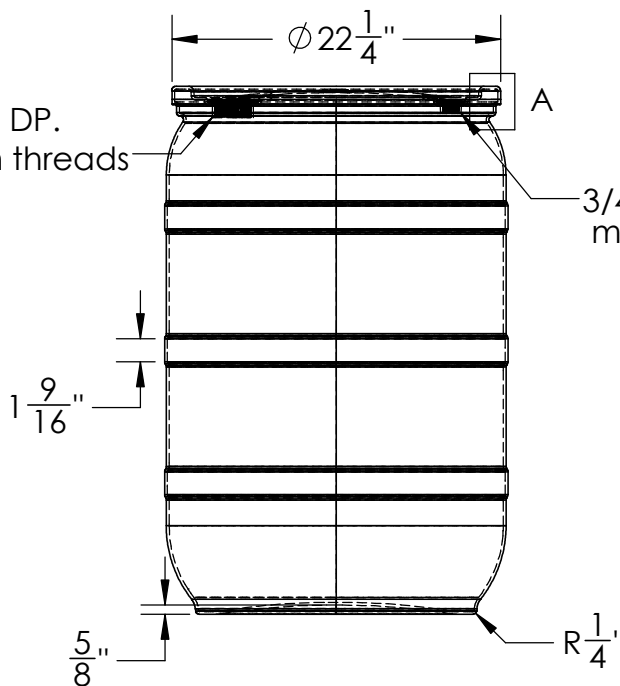

3/4" NPS x 3/4" DP.  
molded in threads

55 Gallon Closed Head Drum



1390 Neubrecht Road  
Lima, Ohio 45801

STOCK NO. 5369, 5370, 5371,  
5372, 5373, 5374

REV  
**A**

DO NOT SCALE DRAWING

WEIGHT: 21 lbs.

|   |                   |  |            |
|---|-------------------|--|------------|
| DIMENSIONS ARE IN INCHES<br>TOLERANCE: $\pm 1/4"$ |                   | NAME   | DATE       |
| MATERIAL  | LLDPE - FDA resin | DRAWN  | JMP 7/1/19 |
| CAPACITY  | 55 Gallon         | APPROVED   |            |
| GRADUATIONS                                       | N/A               | REVISIONS  |            |
| NOMINAL WALL THICKNESS                            | 3/16"             | COMMENTS:<br>Black, Blue, Red<br>Yellow, Natural, Green<br>UV Stabilized |            |

**PROPRIETARY AND CONFIDENTIAL**

THE INFORMATION CONTAINED IN THIS  
DRAWING IS THE SOLE PROPERTY OF  
TAMCO. ANY REPRODUCTION IN PART  
OR AS A WHOLE WITHOUT THE WRITTEN  
PERMISSION OF TAMCO IS PROHIBITED.

MAX. OPERATING TEMP. 140°F  
INTERMITTENT SERVICE TO 160°F  
SEE CHEMICAL RESISTANCE  
CHART FOR COMPATIBILITY